



Ball-Bearing Products

www.daytonlamina.com
Check our website for the latest
technical information.

Ball-Bearing Components

CONTENTS

Ball-Bearing Operating Data & Design Selection	2
Ball-Bearing Component Installation Instructions.....	3
Ball-Bearing Assembly Lubrication Recommendation.....	3
Ball-Bearing Clamps & Screws.....	4
Ball-Bearing Boring Procedures & Dimensions for Precision Dies.....	5
Ball-Bearing Retainers.....	6
Ball-Bearing Sleeve Bushings – Pressed Fit.....	7
Ball-Bearing Bushings – Tap Fit	8
Ball-Bearing Guide Posts – Pressed Fit	9
Ball-Bearing Guide Posts – Tap Fit.....	10
Ball-Bearing Retainers – Metric.....	11
Ball-Bearing Bushings – Sleeve– Metric	12
Ball-Bearing Bushings – Tap Fit – Metric.....	13
Ball-Bearing Guide Posts – Straight – Metric	14
Ball-Bearing Guide Posts – Tap Fit – Metric.....	15

Ball-Bearing Operating Data & Design Selection

In component selection, varied characteristics must be taken into consideration when selecting length of guide post, bushing and ball-bearing retainer, such as stroke, shut height and type of operation. To help in your selection, we have supplied engineering data and instructions that should be used as a guide when making your component selection. The following conditions should be considered for the most effective performance in a specific application.

In this condition the guide post, bushing and ball-bearing retainer remain in full contact throughout the stroke cycle. This selection is beneficial and recommended for high speed, high production, short stroke dies.

This may be accomplished by selecting the bushing length that allows the guide post to disengage the bushing at the beginning of the stroke or cycle. This will result in the loss of pre-load while the ball-bearing retainer is still within the bushing.

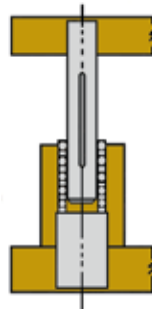

**FULL CONTACT
PRE-LOAD**

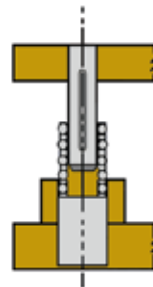

**PRE-LOAD RELIEVED
AT TOP OF STROKE**

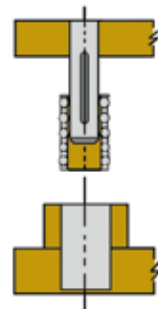

**FULL
DISENGAGEMENT**

This condition may be utilized with long stroke dies. It also provides safe operation by eliminating pinch points and prevents foreign materials from entering the bushing. A further benefit is it allows for registration of the ball-bearing retainer on each stroke. Removal of the punch holder or die holder from press is possible without total removal of dies.

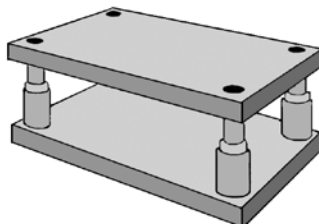

This condition is permissible when the ball retainer must totally disengage the bushing on applications requiring long strokes. Safety precautions (as outlined on page 16) should always be taken when employing this method.

It should also be noted that the above illustration depicts the proper way to assemble (insert) the guide post and ball-bearing retainer into the bushing.

When in a pre-loaded (rolling press fit) condition, the ball-bearing retainer will travel half the distance of movement. In a die set application it would be half the distance of the press stroke.

Ball-Bearing Component Installation Instructions

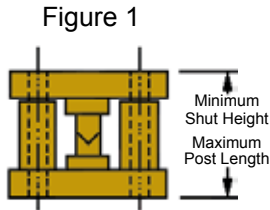

Figure 1
Punch Holder in contact with Bushing
Punch and die life depleted

Figure 1 (Minimum Shut Height) determines maximum guide post length and maximum bushing height. This will prevent post bottoming on bolster at minimum shut height if nominal post length is same as minimum shut height.

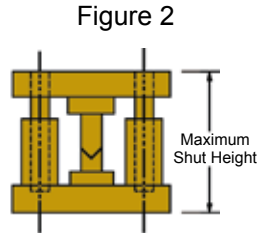
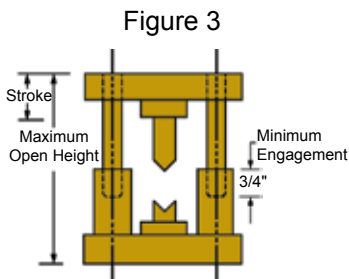

Figure 2
New Punch and Die

The maximum shut height added to the stroke equals the maximum open height (Figure 3) indicating the minimum engagement for the guide post in the required bushing. It is considered ideal for the minimum engagement to be at least 3/4". If it is less than 3/4", however, the arrangement shown in Figure 4 is recommended.

Keeping in mind that only a small part of the stroke on most dies actually does the work, when conditions shown in Figure 4 are acceptable, together with conditions shown in Figures 1 and 2, there is no need to be concerned with the full length of the stroke and maximum open height.



When required strokes are longer than normal, guide post and retainer, if necessary, may be totally disengaged from bushing on the upward travel, provided (A) operation is vertical, (B) operation is limited to no more than 150 strokes per minute, (C) the ram and gib alignment of the press are accurate.

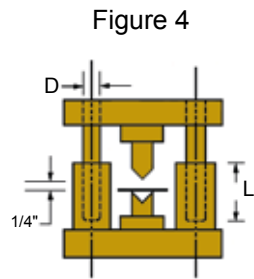

The bushing must always be engaged by the guide post minimum of 3/4" if the operation is included or if speed surpasses 150 strokes per minute. The guide post bushing must engage the retainer during the entire operation, or what is known as full contact pre-load operation.

GENERAL INFORMATION SPECIFICATIONS

1. The ball-bearing retainer travels half the distance the pin travels or one-half the stroke length.
2. The maximum post length equals(=) minimum shut height minus (-) 1/4" Figure 1. If post length should be greater than minimum shut height it will be necessary to provide clearance for projecting post when press is at bottom of stroke.
3. Maximum straight sleeve length Figure 1 equals (=) minimum shut height minus (-) punch holder thickness minus (-) 1/4". Select nearest standard length.
4. Maximum retainer length equals (=) bushing length minus (-) 1/2".

Post slot lengths available upon request.

Ball-Bearing Assembly Lubrication Recommendation

In operation of ball assembly, add lubricant once each 8-hour shift by spray or brush application. Use a lightweight spindle oil like Lamina BALL-LUBE®. **NEVER USE GREASE.**

BALL-SCRUBB® removes heavy soils, dirt or grease from ball-bearing guide pin assemblies.

Just spray it on, wait 3 minutes and spray again. Then blow off excess with compressed air.

BALL-SCRUBB® is an industrial strength cleaner with rust inhibitors, specially formulated to clean debris and grease from all types of ball-bearing assemblies.

BALL-LUBE®, when applied after **BALL-SCRUBB®**, locks out wear by chemically bonding to precision surfaces. It provides a tough, long-lasting shield that protects against oxidation and rust.

BALL-LUBE® lubricates assemblies and gives them longtime protection against wear, oxidation and heat.

Spray liberally on ball-bearing assemblies.

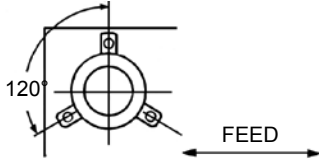
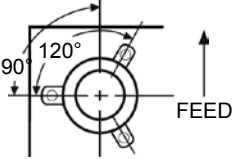
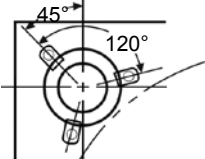
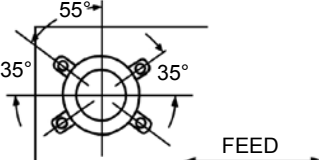
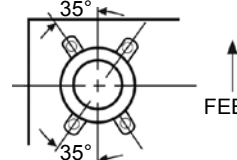
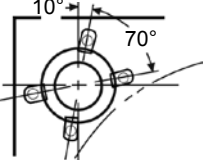
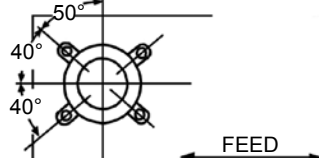
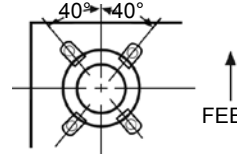
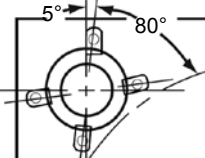
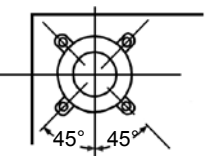
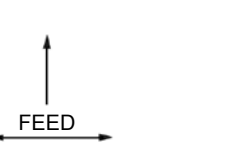
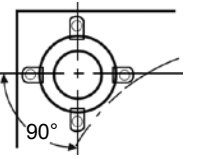

BALL-LUBE® & BALL-SCRUBB®			
PART NUMBER	DESCRIPTION	PART NUMBER	DESCRIPTION
ARL016	1 Pint BALL-LUBE® spray	ARS016	1 Pint BALL-SCRUBB® Spray
ARL384	1 Case (24) 1 Pint BALL-LUBE®	ARS384	1 Case (24) 1 Pint BALL-SCRUBB®
ARL128	1 Gallon BALL-LUBE®	ARS128	1 Gallon BALL-SCRUBB®
ARL640	5 Gallons BALL-LUBE®	ARS640	5 Gallons BALL-SCRUBB®

BALL-BEARING DEMOUNTABLE COMPONENT CLAMP ARRANGEMENTS				BOLT CIRCLE DIAMETERS	
Nom. Pin Dia.	Standard Left-Right Feed	Front to Back Feed (Center Post die Sets)	Round Dies	DEMOUNTABLE BALL-BEARING BUSHINGS	
				Nom. Bushing Diameter	Bolt Circle Diameter
1, 1¼ & 1½				1	2.438
				1-1/4	2.813
				1-1/2	3.125
				1-3/4	3.438
1¾, 2, 2½ & 3				2	4.000
				2-1/2	4.500
				3	5.000
1¾, 2, 2½ & 3				DEMOUNTABLE BALL-BEARING PINS	
				Nom. Pin Diameter	Bolt Circle Diameter
				1	1.750
				1-1/4	2.000
				1-1/2	2.250
1¾, 2, 2½ & 3				1-3/4	2.625
				2	2.875
				2-1/2	3.375
3	3.875				

TOE CLAMP DIMENSIONS

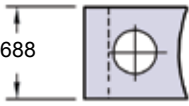
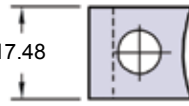
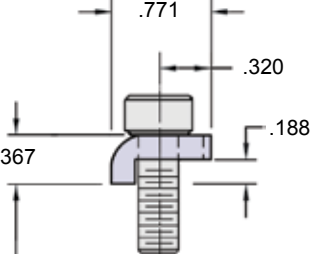
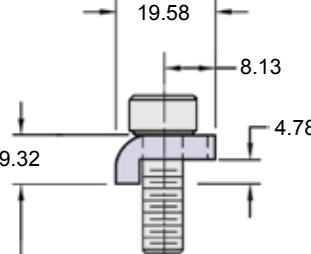
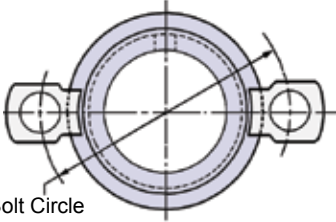
INCH	METRIC	
		
		
<p>x-40-Clamp & 5/16-18x3/4 Screw</p>	<p>X-40-Clamp & F010810 Metric Screw (M8 x 1.25-20mm)</p>	<p>Bolt Circle Diameter</p> <p>Drawing above refers to X-40 Clamps</p>

REPLACEMENT KITS CLAMPS & SCREWS – X40-CLAMPS							
PART NUMBER	Nom. Pin Diameters	# Clamps & Screws per Kit	No. of Kits Needed	PART NUMBER	Nom. Pin Diameters	# Clamps & Screws per Kit	No. of Kits Needed
CSK200002	5/8 - 7/8	2	1	CSK20052	18 - 19	2	1
CSK200003	1 - 1-3/4	3	1	CSK20053	24 - 42	3	1
CSK200002	2 - 2-1/2	2	2	CSK20052	50 - 80	2	2
CSK200003	3 - 4-1/2	3	2				

Ball-Bearing Boring Procedures & Dimensions for Precision Dies

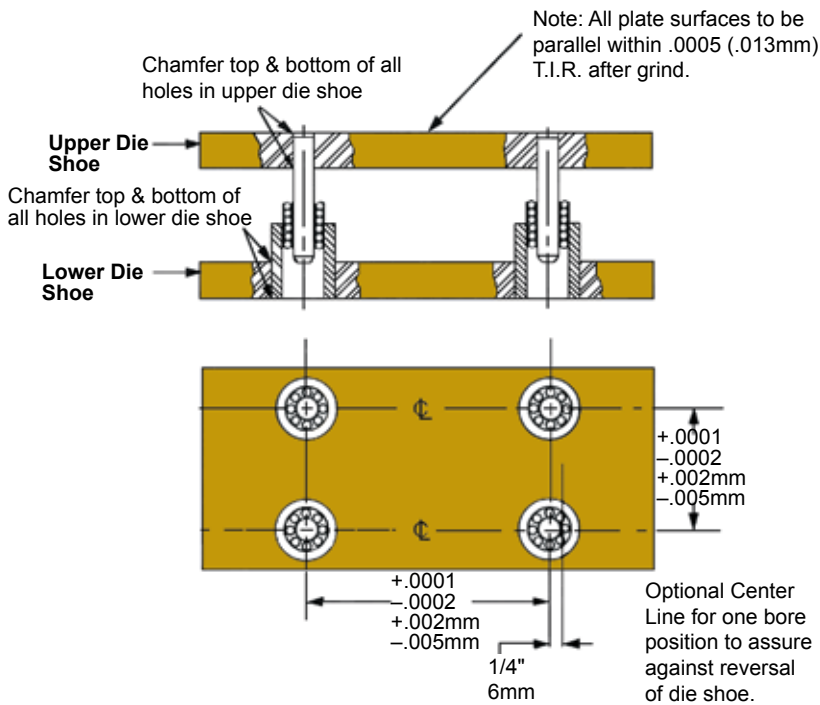

1. Grind die shoe plates parallel within .0005 per foot (.013mm). Then deburr and thoroughly clean plates.

2. Clamp upper and lower shoes together and mount in boring machine.

3. Sweep and strip top surface of plate in boring machine. Shim as required to achieve "0" indicator reading of $(\begin{smallmatrix} +.0001 & +.002\text{mm} \\ -.0002 & -.005\text{mm} \end{smallmatrix})$ T.I.R. All bores to the square to plate surfaces within $(\begin{smallmatrix} +.0001 & +.002\text{mm} \\ -.0002 & -.005\text{mm} \end{smallmatrix})$ T.I.R.

4. Step bore in line with hole patterns to dimensions show on chart. All bores to be square to plate surfaces within $(\begin{smallmatrix} +.0001 & +.002\text{mm} \\ -.0002 & -.005\text{mm} \end{smallmatrix})$ T.I.R.

5. Chamfer both ends of bore.

Complete interchangeability of Lamina ball-bearing guide pins, bushings and retainers makes select fitting unnecessary. No modifications, such as grinding, honing or lapping will be required if mounting and boring instructions which are shown on this page are carefully followed.

BORE SIZE CHART FOR BALL-BEARING BUSHINGS & PINS

Nominal Guide Pin Diameter	BORE SIZE for Tap Fit of Steel Sleeve Bushings AB1 & ABM	BORE SIZE for WRING FIT of Demountable Steel Guide Bushings ABG	BORE SIZE for PRESS FIT of Straight Guide Pins AP1 & APM	BORE SIZE for Tap Fit of Demountable Flanged Guide Pins APG
3/4	1.3872 / 1.3867	N/A	.7515 / .7510	N/A
1	1.7172 / 1.7167	1.7168 / 1.7163	1.0015 / 1.0010	1.0016 / 1.0011
1-1/4	2.1072 / 2.1067	2.1068 / 2.1063	1.2510 / 1.2505	1.2516 / 1.2511
1-1/2	2.4372 / 2.4367	2.4368 / 2.4363	1.5010 / 1.5005	1.5016 / 1.5011
1-3/4	2.7472 / 2.7467	2.7468 / 2.7463	1.7510 / 1.7505	1.7516 / 1.7511
2	3.1622 / 3.1617	3.1618 / 3.1613	2.0006 / 2.0001	2.0016 / 2.0011
2-1/2	3.6822 / 3.6817	3.6818 / 3.6813	2.5006 / 2.5001	2.5016 / 2.5011
3	4.1822 / 4.1817	4.1818 / 4.1813	3.0006 / 3.0001	3.0016 / 3.0011
32mm	54.005 / 53.995	53.972 / 53.960	31.959 / 31.945	31.965 / 31.953
40mm	65.005 / 64.995	64.972 / 64.956	39.959 / 39.945	39.964 / 39.952
50mm	81.005 / 80.995	80.971 / 80.959	49.949 / 49.932	49.964 / 49.952
63mm	95.005 / 94.995	94.972 / 94.960	62.949 / 62.932	62.964 / 62.952
80mm	112.005 / 111.995	111.972 / 111.960	79.949 / 79.932	79.964 / 79.952

Straight Sleeve Bushing Installation Instructions

In order to avoid the bushing close-in which occurs as a result of pressfit, these bushings should be retained with a Bushing Mount. When so installed, it is not necessary to hone the bushing bore after installation, and the bushing fit will be correct.

APPLICATION OF BUSHING MOUNT

1. Degrease bushing OD and die shoe bore with alcohol, acetone or other volatile solvent and wipe dry.
2. Apply Bushing Mount sparingly and wring bushing into die shoe.

3. Allow a 4-hour cure at 72° F. Do not disturb bushing until cure is complete.

BUSHING MOUNT:
Part number 9-60-82

Ball-Bearing – Retainers

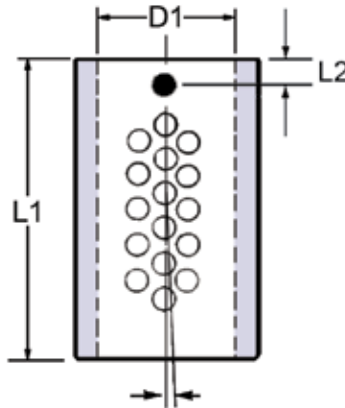

Radial placement reduces wear and tracking

Lamina ball-bearing retainers (AR1) are made of a heat-treated aluminum alloy that combines lightness and strength.

Each retainer is quality inspected for dimensional tolerance and all burrs are removed prior to ball insertion.

Ball bearings are of the highest quality AAA1 Grade (25 millionth class), continually inspected to meet our exacting tolerance.

After the ball bearings have been inserted into the retainer, they are then staked using Lamina's unique method that allows free movement with maximum security.

After staking, the retainers are then scrubbed to remove all metal particles that could cause accelerated tracking and grooving in the post and bushing.

Ball bearings are placed in retainers in an off-line radial pattern that offers optimum life in high or low speed presses.

Ball-bearing retainers are fastened to the guide post by means of a set screw and slot in guide post and are interchangeable with other manufacturers using this method.

BALL-BEARING RETAINER			
(STANDARD)			
PART NUMBER	D1	L1	L2 SET SCREW
AR1-0606	3/4"	1.50	.250
AR1-0607		1.75	
AR1-0608		2.00	
AR1-0609		2.25	
AR1-0610		2.50	
AR1-0806	1"	1.50	
AR1-0807		1.75	
AR1-0808		2.00	
AR1-0809		2.25	
AR1-0810		2.50	
AR1-1008	1-1/4"	2.00	
AR1-1009		2.25	
AR1-1010		2.50	
AR1-1011		2.75	
AR1-1012		3.00	
AR1-1013	3.25		
AR1-1210	1-1/2"	2.50	
AR1-1211		2.75	
AR1-1212		3.00	
AR1-1213		3.25	
AR1-1214		3.50	
AR1-1215		3.75	
AR1-1411		1-3/4"	
AR1-1412	3.00		
AR1-1413	3.25		
AR1-1414	3.50		
AR1-1415	3.75		
AR1-1416	4.00		
AR1-1417	4.25		
AR1-1613	2"	3.25	
AR1-1614		3.50	
AR1-1615		3.75	
AR1-1616		4.00	
AR1-1617		4.25	
AR1-1618		4.50	
AR1-1622		5.50	
AR1-2018	2-1/2"	4.50	.313
AR1-2020		5.00	
AR1-2022		5.50	
AR1-2024		6.00	
AR1-2025		6.25	
AR1-2026		6.50	
AR1-2028		7.00	
AR1-2420	3"	5.00	
AR1-2424		6.00	
AR1-2428		7.00	

Part numbers highlighted in blue designate that the retainer length is recommended for general die set applications. Lengths not highlighted are for limited space use and special applications.

Ball-Bearing Sleeve Bushings – Pressed Fit

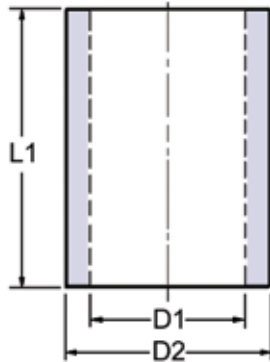

Lamina's Ball-Bearing Guide Assembly Bushings (AB1) are made from vacuum degassed chrome alloy steel, hardened to precise Rockwell limits to give minimum tracking, grooving and downtime.

Lamina's ball-bearing bushings are ground and honed to exacting tolerance limits. Using electronic and air checking instruments on the I.D. and O.D. make them interchangeable and do not require select fitting.

The top is chamfered on the I.D. to minimize wear and aid alignment when disengagement is required.

To minimize bushing close-in which is a result of press fit and to eliminate any additional grinding or honing, boring instructions are provided in this catalog.

BALL-BEARING BUSHINGS – STRAIGHT SLEEVE

PART NUMBER	NOM PIN DIA	D1	D2	L1	PART NUMBER	NOM PIN DIA	D1	D2	L1	PART NUMBER	NOM PIN DIA	D1	D2	L1									
AB1-0607	3/4"	1.1272 1.1269	1.3872 1.3867	1.625	AB1-1214	1-1/2"	1.8771 1.8768	2.4372 2.4367	3.375	AB1-1619	2"	2.5021 2.5018	3.1622 3.1617	4.625									
AB1-0608				1.875	AB1-1215				3.625	AB1-1620				4.875									
AB1-0609				2.125	AB1-1216				3.875	AB1-1621				5.125									
AB1-0610				2.375	AB1-1217				4.125	AB1-1622				5.375									
AB1-0611				2.625	AB1-1218				4.375	AB1-1624				5.875									
AB1-0612				2.875	AB1-1219				4.625	AB1-1626				6.375									
AB1-0613				3.125	AB1-1220				4.875	AB1-1628				6.875									
AB1-0614				3.375	AB1-1221				5.125	AB1-1630				7.375									
AB1-0615				3.625	AB1-1222				5.375	AB1-1632				7.875									
AB1-0616				3.875	AB1-1224				5.875	AB1-1634				8.375									
AB1-0618				4.375	AB1-1226				6.375	AB1-1636				8.875									
AB1-0624				5.875	AB1-1230				7.375	AB1-1640				9.875									
AB1-0808				1"	1.3772 1.3769				1.7172 1.7167	1.875				AB1-1232	1-3/4"	2.1270 2.1267	2.7472 2.7467	7.875	AB1-1642	2-1/2"	3.0021 3.0018	3.6822 3.6817	10.375
AB1-0809										2.125				AB1-1234				8.375	AB1-1644				10.875
AB1-0810	2.375	AB1-1236	8.875			AB1-1648	11.875																
AB1-0811	2.625	AB1-1240	9.875			AB1-1652	12.875																
AB1-0812	2.875	AB1-1242	10.375			AB1-1656	13.875																
AB1-0813	3.125	AB1-1244	10.875			AB1-2022	5.375																
AB1-0814	3.375	AB1-1248	11.875			AB1-2024	5.875																
AB1-0815	3.625	AB1-1412	2.875			AB1-2026	6.375																
AB1-0816	3.875	AB1-1414	3.375			AB1-2028	6.875																
AB1-0817	4.125	AB1-1415	3.625			AB1-2030	7.375																
AB1-0818	4.375	AB1-1416	3.875			AB1-2032	7.875																
AB1-0819	4.625	AB1-1417	4.125			AB1-2034	8.375																
AB1-0820	4.875	AB1-1418	4.375			AB1-2036	8.875																
AB1-0822	5.375	AB1-1419	4.625			AB1-2038	9.375																
AB1-0824	5.875	AB1-1420	4.875	AB1-2040	9.875																		
AB1-0826	6.375	AB1-1421	5.125	AB1-2042	10.375																		
AB1-0828	6.875	AB1-1422	5.375	AB1-2044	10.875																		
AB1-1010	1-1/4"	1.6271 1.6268	2.1072 2.1067	2.375	AB1-1424	2"	2.5021 2.5018	3.1622 3.1617	5.875	AB1-2048	3"	3.5020 3.5017	4.1822 4.1817	11.875									
AB1-1011				2.625	AB1-1426				6.375	AB1-2052				12.875									
AB1-1012				2.875	AB1-1428				6.875	AB1-2056				13.875									
AB1-1013				3.125	AB1-1430				7.375	AB1-2424				5.875									
AB1-1014				3.375	AB1-1432				7.875	AB1-2426				6.375									
AB1-1015				3.625	AB1-1434				8.375	AB1-2428				6.875									
AB1-1016				3.875	AB1-1436				8.875	AB1-2430				7.375									
AB1-1017				4.125	AB1-1438				9.375	AB1-2432				7.875									
AB1-1018				4.375	AB1-1440				9.875	AB1-2434				8.375									
AB1-1019				4.625	AB1-1442				10.375	AB1-2436				8.875									
AB1-1020				4.875	AB1-1444				10.875	AB1-2438				9.375									
AB1-1022				5.375	AB1-1448				11.875	AB1-2440				9.875									
AB1-1024				5.875	AB1-1452				12.875	AB1-2442				10.375									
AB1-1026				6.375	AB1-1612				2.875	AB1-2444				10.875									
AB1-1028	6.875	AB1-1614	3.375	AB1-2448	11.875																		
AB1-1032	7.875	AB1-1615	3.625	AB1-2452	12.875																		
AB1-1036	8.875	AB1-1616	3.875	AB1-2456	13.875																		
AB1-1212	1-1/2"	1.8771 1.8768	2.4372 2.4367	2.875	AB1-1617	See page 5 for bore size information.																	
AB1-1213				3.125	AB1-1618										4.125								
														4.375									

Ball-Bearing – Bushings – Tap Fit

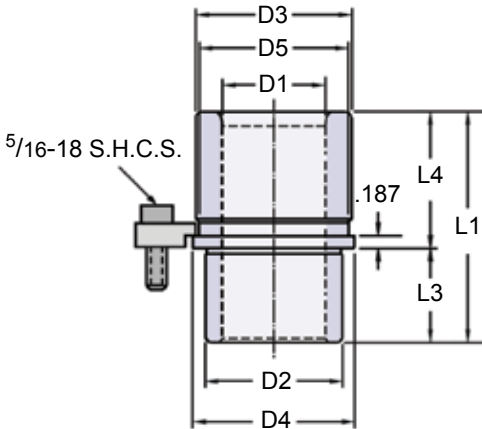

Demountable shoulder bushings offer all the advantages of straight sleeve bushings and combine them with the convenience of easy assembly and disassembly.

These clamp type bushings are meant to be wring fit into the die shoe and should never be forced or inserted by hammering.

X-40-Clamps and socket head screws are provided to hold the bushings in place.

**Clamping information is on page 4.
See page 5 for bore size information.**

Unground demountable bushings are available by special order only.

BALL-BEARING BUSHINGS – DEMOUNTABLE									
PART NUMBER	NOM PIN DIA	D1	D2	D3	D4	D5	L1	L3	L4
ABG0808	1"	1.3772 1.3769	1.7163 1.7160	1.920	1.995	1.775	1.875	1.000	0.875
ABG0809							2.125		1.125
ABG0811							2.625		1.625
ABG0812							2.875		1.875
ABG0813							3.125		2.125
ABG0814							3.375		2.375
ABG0815	3.625	2.625							
ABG1010	1-1/4"	1.6271 1.6268	2.1063 2.1060	2.200	2.355	2.125	2.375	1.000	1.375
ABG1011							2.625		1.625
ABG1012							2.875		1.875
ABG1013							3.125		2.125
ABG1014							3.375		2.375
ABG1015							3.625		2.625
ABG1016							3.875		2.875
ABG1017							4.125		3.125
ABG1018							4.375		3.375
ABG1020							4.875		3.875
ABG1022	5.375	4.375							
ABG1024	5.875	4.875							
ABG1212	1-1/2"	1.8771 1.8768	2.4363 2.4360	2.500	2.675	2.425	2.875	1.250	1.625
ABG1213							3.125		1.875
ABG1214							3.375		2.125
ABG1215							3.625		2.375
ABG1216							3.875		2.625
ABG1217							4.125		2.875
ABG1218							4.375		3.125
ABG1219							4.625		3.375
ABG1220							4.875		3.625
ABG1222							5.375		4.125
ABG1224	5.875	4.625							
ABG1412	1-3/4"	2.1270 2.1267	2.7463 2.7460	2.875	2.995	2.755	2.875	1.250	1.625
ABG1414							3.375		2.125
ABG1416							3.875		2.625
ABG1417							4.125		2.875
ABG1418							4.375		3.125
ABG1419							4.625		3.375
ABG1420							4.875		3.625
ABG1421							5.125		3.875
ABG1422							5.375		4.125
ABG1424							5.875		4.625
ABG1426	6.375	5.125							
ABG1428	6.875	5.625							
ABG1430	7.375	6.125							
ABG1612	2"	2.5021 2.5018	3.1613 3.1610	3.375	3.565	3.295	2.875	1.250	1.625
ABG1614							3.375		2.125
ABG1615							3.625		2.375
ABG1616							3.875		2.625
ABG1617							4.125		2.875
ABG1618							4.375		3.125
ABG1619							4.625		3.375
ABG1620							4.875		3.625
ABG1621							5.125		3.875
ABG1622							5.375		4.125
ABG1624	5.875	4.625							
ABG1626	6.375	5.125							
ABG1628	6.875	5.625							
ABG1630	7.375	6.125							
ABG2011	2-1/2"	3.0021 3.0018	3.6813 3.6810	3.875	4.075	3.765	2.625	1.250	1.375
ABG2020							4.875		3.625
ABG2022							5.375		4.125
ABG2024							5.875		4.625
ABG2026							6.375		5.125
ABG2028							6.875		5.625
ABG2030	7.375	6.125							
ABG2420	3"	3.5020 3.5017	4.1813 4.1810	4.500	4.575	4.275	4.875	1.250	3.625
ABG2422							5.375		4.125
ABG2424							5.875		4.625
ABG2426							6.375		5.125
ABG2428							6.875		5.625
ABG2430							7.375		6.125

Ball-Bearing Guide Posts – Pressed Fit

Lamina's Precision Guide Post (AP1) for ball-bearing assemblies are made from chrome alloy steel, hardened to provide maximum protection against tracking and accelerated wear.

Ground to a high degree of tolerance accuracy that also provides a smooth hard wearing surface to assure free rolling of balls to maintain constant, predictable preload and complete interchangeability, not only with our own but other manufacturers' also.

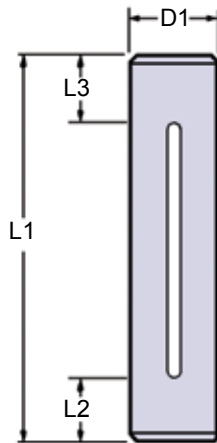

BALL-BEARING GUIDE POSTS – STRAIGHT											
PART NUMBER	NOM PIN DIA	D1	L1	L2	L3	PART NUMBER	NOM PIN DIA	D1	L1	L2	L3
AP1-0612	3/4"	.7530 .7527	2.875	0.625	0.813	AP1-1422	1-3/4"	1.7530 1.7525	5.375	1.313	1.313
AP1-0613			3.125	0.625	0.813	AP1-1423			5.625	1.500	1.500
AP1-0614			3.375	0.625	0.813	AP1-1424			5.875	1.500	1.500
AP1-0615			3.625	0.625	0.813	AP1-1425			6.125	1.500	1.500
AP1-0616			3.875	0.625	0.813	AP1-1426			6.375	1.625	1.750
AP1-0617			4.125	0.625	0.813	AP1-1428			6.875	1.625	1.750
AP1-0618			4.375	0.625	0.813	AP1-1430			7.375	1.625	1.750
AP1-0619			4.625	0.875	1.000	AP1-1432			7.875	1.625	1.750
AP1-0620			4.875	0.875	1.000	AP1-1434			8.375	1.625	1.750
AP1-0622			5.375	0.875	1.000	AP1-1436			8.875	1.625	2.250
AP1-0624	5.875	0.875	1.000	AP1-1438	9.375	1.625	2.250				
AP1-0815	1"	1.0030 1.0027	3.625	0.875	1.000	AP1-1440	2"	2.0031 2.0026	9.875	1.625	2.250
AP1-0816			3.875	0.875	1.000	AP1-1442			10.375	1.625	2.250
AP1-0817			4.125	0.875	1.000	AP1-1444			10.875	1.625	2.250
AP1-0818			4.375	0.875	1.000	AP1-1446			11.375	1.625	2.250
AP1-0819			4.625	0.875	1.250	AP1-1448			11.875	1.625	2.250
AP1-0820			4.875	0.875	1.250	AP1-1450			12.375	1.625	2.250
AP1-0821			5.125	0.875	1.250	AP1-1452			12.875	1.625	2.875
AP1-0822			5.375	0.875	1.250	AP1-1456			13.875	1.625	2.875
AP1-0823			5.625	0.875	1.250	AP1-1460			14.875	1.625	2.875
AP1-0824			5.875	0.875	1.250	AP1-1468			16.875	1.625	2.875
AP1-0826	6.375	0.875	1.500	AP1-1622	5.375	1.375	1.500				
AP1-0828	6.875	0.875	1.500	AP1-1623	5.625	1.375	1.500				
AP1-0830	7.375	0.875	1.500	AP1-1624	5.875	1.375	1.500				
AP1-0832	7.875	0.875	1.500	AP1-1625	6.125	1.375	1.500				
AP1-0834	8.375	0.875	2.000	AP1-1626	6.375	1.750	1.875				
AP1-0836	8.875	0.875	2.000	AP1-1627	6.625	1.750	1.875				
AP1-1018	1-1/4"	1.2530 1.2526	4.375	1.000	1.375	AP1-1628	2-1/2"	2.5031 2.5026	6.875	1.750	1.875
AP1-1019			4.625	1.000	1.375	AP1-1629			7.125	1.750	1.875
AP1-1020			4.875	1.000	1.375	AP1-1630			7.375	1.750	1.875
AP1-1021			5.125	1.000	1.375	AP1-1631			7.625	1.750	1.875
AP1-1022			5.375	1.000	1.375	AP1-1632			7.875	1.750	1.875
AP1-1023			5.625	1.000	1.375	AP1-1634			8.375	1.875	2.250
AP1-1024			5.875	1.000	1.375	AP1-1636			8.875	1.875	2.250
AP1-1026			6.375	1.125	1.750	AP1-1638			9.375	1.875	2.250
AP1-1028			6.875	1.125	1.750	AP1-1640			9.875	1.875	2.250
AP1-1030			7.375	1.125	1.750	AP1-1642			10.375	1.875	2.250
AP1-1032	7.875	1.125	1.750	AP1-1644	10.875	1.875	2.250				
AP1-1034	8.375	1.125	1.750	AP1-1646	11.375	1.875	3.000				
AP1-1036	8.875	1.125	1.750	AP1-1648	11.875	1.875	3.000				
AP1-1040	9.875	1.125	2.250	AP1-1650	12.375	1.875	3.000				
AP1-1044	10.875	1.125	2.250	AP1-1652	12.875	1.875	3.000				
AP1-1048	11.875	1.175	2.250	AP1-1656	13.875	2.375	3.000				
AP1-1218	1-1/2"	1.5030 1.5026	4.375	1.375	1.313	AP1-1660	3"	3.0031 3.0025	14.875	1.875	3.000
AP1-1219			4.625	1.375	1.313	AP1-1664			15.875	1.875	3.000
AP1-1220			4.875	1.375	1.313	AP1-1668			16.875	1.875	3.000
AP1-1221			5.125	1.375	1.313	AP1-1672			17.875	1.875	3.000
AP1-1222			5.375	1.375	1.313	AP1-2032			7.875	1.625	2.500
AP1-1223			5.625	1.250	1.563	AP1-2034			8.375	1.625	2.500
AP1-1224			5.875	1.250	1.563	AP1-2036			8.875	2.375	2.750
AP1-1226			6.375	1.250	1.563	AP1-2040			9.875	2.375	3.000
AP1-1228			6.875	1.375	2.000	AP1-2044			10.875	2.375	3.000
AP1-1230			7.375	1.375	2.000	AP1-2048			11.875	2.375	3.000
AP1-1232	7.875	1.375	2.000	AP1-2052	12.875	2.375	3.000				
AP1-1234	8.375	1.375	2.000	AP1-2056	13.875	2.375	3.000				
AP1-1236	8.875	1.625	2.500	AP1-2068	16.875	2.625	4.000				
AP1-1238	9.375	1.625	2.500	AP1-2080	19.875	2.625	4.000				
AP1-1240	9.875	1.625	2.500	AP1-2432	7.875	2.000	2.375				
AP1-1242	10.375	1.625	2.500	AP1-2434	8.375	1.875	2.500				
AP1-1244	10.875	1.625	2.500	AP1-2436	8.875	1.875	2.500				
AP1-1246	11.375	1.625	2.500	AP1-2440	9.875	2.875	3.000				
AP1-1248	11.875	1.625	2.500	AP1-2444	10.875	2.875	3.000				
AP1-1250	12.375	1.625	2.500	AP1-2448	11.875	2.875	3.000				
AP1-1252	12.875	1.625	2.500	AP1-2452	12.875	2.875	3.000				
AP1-1256	13.875	1.625	2.500	AP1-2456	13.875	2.875	3.000				
AP1-1420	1-3/4"	1.7530 1.7525	4.875	1.313	1.313	AP1-2468	3"	3.0031 3.0025	16.875	2.875	4.000
AP1-1421			5.125	1.313	1.313	AP1-2480			19.875	2.875	4.000

Ball-Bearing Guide Posts – Tap Fit

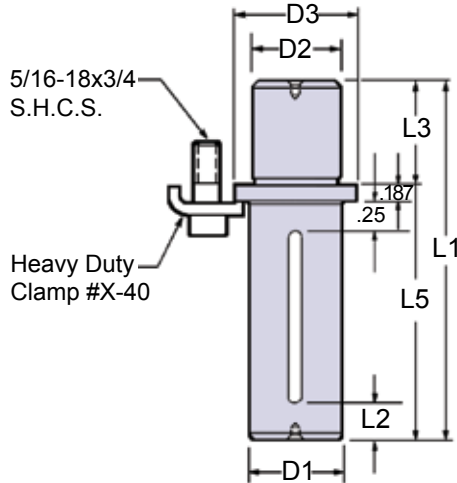

Designed to expedite die repair, these Ball-Bearing flanged guide posts offer:

- Large savings in maintenance, repair costs and downtime
- Wide variety of sizes
- Long, trouble-free production runs
- Highest quality workmanship and materials
- “D2” dimension is finished ground

Clamps & Screws included

Pins with unground D2 dimensions are available as specials.

BALL-BEARING GUIDE POSTS – DEMOUNTABLE																		
PART NUMBER	NOM PIN DIA	D1	D2	D3	L1	L2	L3	L5	PART NUMBER	NOM PIN DIA	D1	D2	D3	L1	L2	L3	L5	
APG0815	1"	1.0030 1.0027	1.0011 1.0006	1.312	3.625	0.875	1.188	2.437	APG1626	2"	2.0031 2.0026	2.0011 2.0006	2.500	6.375	1.375	1.938	4.437	
APG0819					4.625			3.437	APG1627					6.625	1.375		4.687	
APG0820					4.875			3.687	APG1628					6.875	1.625		4.937	
APG0821					5.125			3.937	APG1629					7.125	1.625		5.187	
APG0824					5.875			4.687	APG1630					7.375	1.625		5.437	
APG0826					6.375			5.187	APG1632					7.875	1.625		5.937	
APG0828					6.875			5.687	APG1634					8.375	1.625		6.437	
APG0830					7.375			6.187	APG1636					8.875	1.625		6.937	
APG0836					8.875			7.687	APG1638					9.375	1.875		7.437	
APG1021	1-1/4"	1.2530 1.2526	1.2511 1.2506	1.562	5.125	0.875	1.188	3.937	APG1640	2-1/2"	2.5031 2.5026	2.5011 2.5006	3.000	9.875	1.875	1.938	7.937	
APG1022					5.375	0.875		4.187	APG1642					10.375	1.875		8.437	
APG1023					5.625	0.875		4.437	APG1644					10.875	1.875		8.937	
APG1026					6.375	0.875		5.187	APG1648					11.875	1.875		9.937	
APG1028					6.875	0.875		5.687	APG1650					11.375	1.875		10.437	
APG1030					7.375	0.875		6.187	APG1652					12.875	1.875		10.937	
APG1032					7.875	1.125		6.687	APG1656					13.875	1.875		11.937	
APG1034					8.375	1.125		7.187	APG1660					14.875	1.875		12.937	
APG1036					8.875	1.125		7.687	APG1664					15.875	1.875		13.937	
APG1218	1-1/2"	1.5030 1.5026	1.5011 1.5006	1.875	4.375	1.125	1.438	2.937	APG1668	2-1/2"	2.5031 2.5026	2.5011 2.5006	3.000	16.875	1.875	1.938	14.937	
APG1222					5.375	1.125		3.937	APG1672					17.875	1.875		15.937	
APG1223					5.625	1.125		4.187	APG2032					7.875	2.375		5.937	
APG1224					5.875	1.125		4.437	APG2034					8.375	2.375		6.437	
APG1226					6.375	1.125		4.937	APG2036					8.875	2.375		6.937	
APG1228					6.875	1.375		5.437	APG2040					9.875	2.375		7.937	
APG1230					7.375	1.375		5.937	APG2044					10.875	2.375		8.937	
APG1234					8.375	1.375		6.937	APG2048					11.875	2.375		9.937	
APG1236					8.875	1.375		7.437	APG2052					12.875	2.375		10.937	
APG1238	9.375	1.375	7.937	APG2056	13.875	2.375	11.937											
APG1242	10.375	1.375	8.937	APG2068	16.875	2.375	14.937											
APG1424	1-3/4"	1.7530 1.7525	1.7511 1.7506	2.250	5.875	1.375	1.688	4.187	APG2080	3"	3.0031 3.0025	3.0011 3.0006	3.500	19.875	2.375	2.438	17.937	
APG1428					6.875	1.375		5.187	APG2432					7.875	1.875		5.437	
APG1430					7.375	1.375		5.687	APG2434					8.375	1.875		5.937	
APG1432					7.875	1.375		6.187	APG2436					8.875	1.875		6.437	
APG1434					8.375	1.375		6.687	APG2440					9.875	2.375		7.437	
APG1436					8.875	1.625		7.187	APG2444					10.875	2.375		8.437	
APG1438					9.375	1.625		7.687	APG2448					11.875	2.375		9.437	
APG1440					9.875	1.625		8.187	APG2452					12.875	2.875		10.437	
APG1442					10.375	1.625		8.687	APG2456					13.875	2.875		11.437	
APG1448	11.875	1.625	10.187	APG2468	16.875	2.875	14.437											
See page 4 for toe clamp placement instructions.									APG2480							19.875	2.875	17.437

Lamina offers a generous range of Metric Ball-Bearing Components to suit your needs.

- Retainers
- Sleeve Bushings
- Tap-Fit Bushings (Demountable)
- Straight Pins
- Tap-Fit Pins (Demountable)

Specials are available.

Ball-Bearing Retainers – Metric

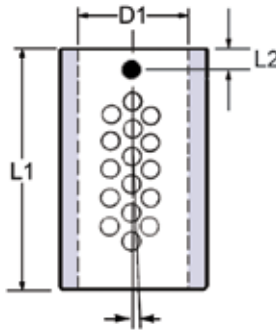

- Heat-Treated Aluminum
- AAA1 Grade Ball Bearings
- Off-line radial pattern
- Set-screw and slot fastening

BALL-BEARING RETAINERS – METRIC			
PART NUMBER	D1 Nom Pin Dia	L1 Length	L2 SET SCREW
ARM032058 ARM032070 ARM032083	32	58 70 83	6.35
ARM040065 ARM040077 ARM040096	40	65 77 96	6.35
ARM050083 ARM050102 ARM050114	50	83 102 114	6.35
ARM063100 ARM063140 ARM063178	63	100 140 178	7.94
ARM080100 ARM080140 ARM080178	80	100 140 178	7.94

Lamina ball-bearing retainers (ARM) are made of a heat-treated aluminum alloy that combines lightness and strength.

Each retainer is quality inspected for dimensional tolerance and all burrs are removed prior to ball insertion.

Ball bearings are of the highest quality AAA1 Grade (25 millionth class), continually inspected to meet our exacting tolerance.

After the ball bearings have been inserted into the retainer, they are then staked using Lamina’s unique method that allows free movement with maximum security.

After staking, the retainers are then scrubbed to remove all metal particles that could cause accelerated tracking and grooving in the post and bushing.

Ball bearings are placed in retainers in an off-line radial pattern that offers optimum life in high or low speed presses.

Ball-bearing retainers are fastened to the guide post by means of a set screw and slot in guide post and are interchangeable with other manufacturers using this method.

Ball-Bearing Sleeve Bushings – Metric

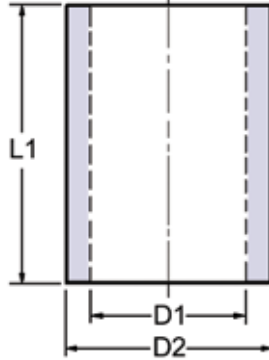

- Vacuum degassed chrome alloy steel
- Ground & honed to exact tolerance limits
- Top chamfered on I.D. to aid in alignment

Lengths up to 300mm – centerless ground
 Lengths over 300mm – ground on centers

BALL-BEARING SLEEVE BUSHINGS – METRIC															
PART NUMBER	NOM PIN DIA	D1	D2	L1	PART NUMBER	NOM PIN DIA	D1	D2	L1						
ABM032075	32	41.986 41.979	54.005 53.995	75	ABM050175	50	63.986 63.978	81.005 80.995	175						
ABM032080				80	ABM050190				190						
ABM032090				90	ABM050200				200						
ABM032095				95	ABM050215				215						
ABM032100				100	ABM050230				230						
ABM032105				105	ABM050250				250						
ABM032115				115	ABM050280				280						
ABM032125				125	ABM050300				300						
ABM032140				140	ABM050330				330						
ABM032150				150	ABM050350				350						
ABM032165				165	ABM063150				150						
ABM032175				175	ABM063165				165						
ABM032200				220	ABM063175				175						
ABM032230				230	ABM063190				190						
ABM040100				40	49.986 49.979				65.005 64.995	100	ABM063200	63	76.985 76.977	95.005 94.995	200
ABM040105										105	ABM063215				215
ABM040115	115	ABM063230	230												
ABM040120	120	ABM063250	250												
ABM040125	125	ABM063280	280												
ABM040135	135	ABM063300	300												
ABM040140	140	ABM063330	330												
ABM040150	150	ABM063350	350												
ABM040165	165	ABM080150	150												
ABM040175	175	ABM080165	165												
ABM040190	190	ABM080175	175												
ABM040200	200	ABM080190	190												
ABM040215	215	ABM080200	200												
ABM040230	230	ABM080215	215												
ABM040250	250	ABM080230	230												
ABM040280	280	ABM080250	250												
ABM040300	300	ABM080280	280												
ABM050125	50	63.986 63.978	81.005 80.995	125	ABM080300	80	93.985 93.977	112.005 111.995	300						
ABM050135				135	ABM080330				330						
ABM050140				140	ABM080350				350						
ABM050150				150	ABM080500				500						
ABM050165				165											

Ball-Bearing Bushings – Tap Fit – Metric



Demountable shoulder bushings offer all the advantages of straight sleeve bushings and combine them with the convenience of easy assembly and disassembly.

These clamp type bushings are meant to be wring fit into the die shoe and should never be forced or inserted by hammering.

X-40-Clamps and socket head screws are provided to hold the bushings in place.

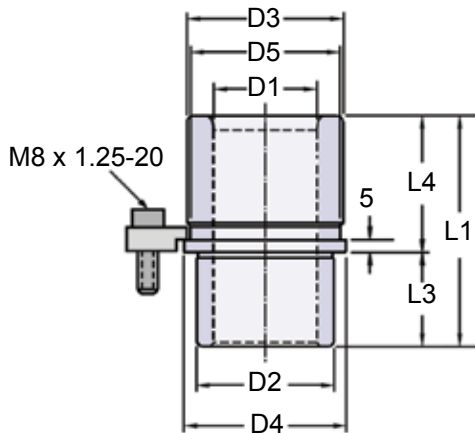

BALL-BEARING BUSHINGS – DEMOUNTABLE – METRIC									
PART NUMBER	NOM PIN DIA	D1	D2	D3	D4	D5	L1	L3	L4
ABGM032065	32	41.986 41.979	53.959 53.951	59.94	61	54.10	65	30	35
ABGM032070							70		40
ABGM032075							75		45
ABGM032080							80		50
ABGM032085							85		55
ABGM032090							90		60
ABGM032095							95		65
ABGM032105							105		75
ABGM032110							110		80
ABGM032115							115		85
ABGM032130							130		100
ABGM032140							140		110
ABGM032155							155		125
ABGM040075							40		49.986 49.979
ABGM040080	80	45							
ABGM040085	85	50							
ABGM040090	90	55							
ABGM040095	95	60							
ABGM040100	100	65							
ABGM040110	110	75							
ABGM040115	115	80							
ABGM040120	120	85							
ABGM040125	125	90							
ABGM040135	135	100							
ABGM040140	140	105							
ABGM040155	155	120							
ABGM050075	50	63.986 63.978	80.959 80.951	85.73	91	84.15	75	35	40
ABGM050090							90		55
ABGM050095							95		60
ABGM050100							100		65
ABGM050110							110		75
ABGM050115							115		80
ABGM050125							125		90
ABGM050135							135		100
ABGM050140							140		105
ABGM050155							155		120
ABGM050165							165		130
ABGM050180	180	145							
ABGM050190	190	155							
ABGM063125	63	76.985 76.977	94.960 94.952	101.85	105	98.43	125	35	90
ABGM063140							140		105
ABGM063155							155		120
ABGM063165							165		130
ABGM063180							180		145
ABGM063190							190		155
ABGM080125							80		93.985 93.977
ABGM080140	140	105							
ABGM080155	155	120							
ABGM080165	165	130							
ABGM080180	180	145							
ABGM080190	190	155							

Ball-Bearing Guide Posts –Straight – Metric

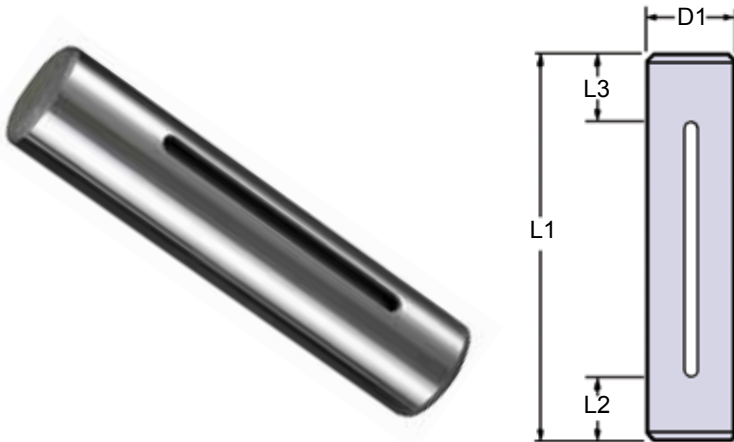

- Hardened chrome alloy steel
- Precision Ground

Lengths up to 300mm – centerless ground
 Lengths over 300mm – ground on centers

BALL-BEARING GUIDE POSTS – METRIC														
PART NUMBER	NOM PIN DIA	D1	L1	L2	L3	# of Slots	PART NUMBER	NOM PIN DIA	D1	L1	L2	L3	# of Slots	
APM032125	32	32.008 32.000	125	25.4	34.9	1	APM050215	50	50.008 50.000	215	47.6	57.2	2	
APM032135			135	25.4	34.9		APM050230			230	47.6	57.2		
APM032140			140	25.4	34.9		APM050240			240	47.6	57.2		
APM032145			145	25.4	34.9		APM050250			250	47.6	57.2		
APM032150			150	28.6	44.5		APM050265			265	47.6	57.2		
APM032165			165	28.6	44.5		APM050280			280	47.6	76.2		
APM032175			175	28.6	44.5		APM050290			290	47.6	76.2		
APM032190			190	28.6	44.5		APM050300			300	47.6	76.2		
APM032200			200	28.6	44.5		APM050315			315	47.6	76.2		
APM032215			215	28.6	44.5		APM050330			330	47.6	76.2		
APM032230			230	28.6	44.5		APM050360			360	47.6	76.2		
APM032250			250	28.6	57.2		APM050380			380	47.6	76.2		
APM032260			260	28.6	57.2		APM050400			400	47.6	76.2		
APM032280			280	28.6	57.2		APM050430			430	47.6	76.2		
APM032300			300	28.6	57.2		APM050460			460	47.6	76.2		
APM040125			40	40.008 40.000	125		34.9			33.3	1	APM063200		63
APM040135	135	34.9			33.3	APM063215	215	41.3	63.5					
APM040140	140	34.9			33.3	APM063230	230	41.3	63.5					
APM040145	145	31.8			39.7	APM063240	240	60.3	76.2					
APM040150	150	31.8			39.7	APM063250	250	60.3	76.2					
APM040165	165	34.9			39.7	APM063265	265	60.3	76.2					
APM040175	175	34.9			50.8	APM063280	280	60.3	76.2					
APM040190	190	34.9			50.8	APM063300	300	60.3	76.2					
APM040200	200	34.9			50.8	APM063315	315	60.3	76.2					
APM040215	215	34.9			50.8	APM063330	330	60.3	76.2					
APM040230	230	41.3			63.5	APM063360	360	60.3	76.2					
APM040240	240	41.3			63.5	APM063380	380	60.3	76.2					
APM040250	250	41.3			63.5	APM063430	430	66.7	101.6					
APM040265	265	41.3			63.5	APM063500	500	66.7	101.6					
APM040280	280	41.3			63.5	APM080200	200	47.6	63.5	2				
APM040290	290	41.3			63.5	APM080215	215	47.6	63.5					
APM040300	300	41.3			63.5	APM080230	230	47.6	63.5					
APM040315	315	41.3			63.5	APM080250	250	73.0	76.2					
APM040330	330	41.3			63.5	APM080280	280	73.0	76.2					
APM040360	360	41.3			63.5	APM080300	300	73.0	76.2					
APM050150	50	50.008 50.000	150	34.9	38.1	2	APM080330	80	80.008 80.000		330	73.0	76.2	
APM050165			165	44.5	47.6		APM080360				360	73.0	76.2	
APM050175			175	44.5	47.6		APM080430				430	73.0	101.6	
APM050190			190	44.5	47.6		APM080500				500	73.0	101.6	
APM050200			200	44.5	47.6									

Ball-Bearing Guide Posts – Tap Fit – Metric

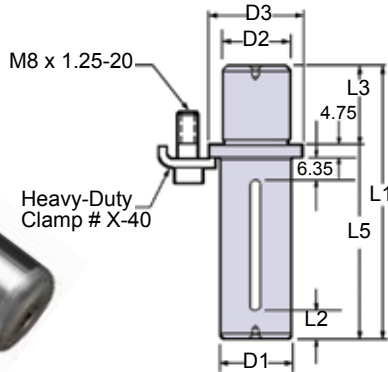

- Large savings in maintenance, repair costs and downtime
- Wide variety of sizes
- Long, trouble-free production runs
- Highest quality workmanship and materials
- “D2” dimension is finished ground

BALL-BEARING GUIDE POSTS – METRIC – Tap Fit

PART NUMBER	NOM PIN DIA	D1	D2	D3	L1	L2	L3	L5	PART NUMBER	NOM PIN DIA	D1	D2	D3	L1	L2	L3	L5		
APGM032115	32	32.008	31.953	40	115	25.4	30	85	APGM050165	50	50.008	49.952	63	165	44.45	49	116		
APGM032120					120	25.4		90	APGM050170					170	44.45		121		
APGM032125					125	25.4		95	APGM050175					175	44.45		126		
APGM032135					135	25.4		105	APGM050180					180	44.45		131		
APGM032140					140	25.4		110	APGM050190					190	44.45		141		
APGM032145					145	25.4		115	APGM050195					195	44.45		146		
APGM032150					150	28.58		120	APGM050200					200	44.45		151		
APGM032165					165	28.58		135	APGM050215					215	47.63		166		
APGM032175					175	28.58		145	APGM050230					230	47.63		181		
APGM032190					190	28.58		160	APGM050240					240	47.63		191		
APGM032200					200	28.58		170	APGM050250					250	47.63		201		
APGM032215					215	28.58		185	APGM050260					260	47.63		211		
APGM032230					230	28.58		200	APGM050280					280	47.63		231		
APGM032250					250	28.58		220	APGM050290					290	47.63		241		
APGM032280					280	28.58		250	APGM050300					300	47.63		251		
APGM032300					300	28.58		270	APGM050315					315	47.63		266		
APGM040115					40	40.008		39.952	48					115	34.93		36	79	APGM050330
APGM040120	120	34.93	84	APGM050360			215			41.28	166								
APGM040125	125	34.93	89	APGM050380			230			41.28	181								
APGM040135	135	34.93	99	APGM050400			250			60.33	201								
APGM040140	140	31.75	104	APGM050430			280			60.33	231								
APGM040145	145	31.75	109	APGM050460			300			60.33	281								
APGM040150	150	31.75	114	APGM063200			330			60.33	311								
APGM040165	165	34.93	129	APGM063215			360			60.33	381								
APGM040175	175	34.93	139	APGM063230			430			66.68	381								
APGM040190	190	34.93	154	APGM063250			500			66.68	451								
APGM040200	200	34.93	164	APGM063280			200			47.6	138								
APGM040215	215	41.28	179	APGM063300			215			47.6	153								
APGM040230	230	41.28	194	APGM063330			230			47.6	168								
APGM040240	240	41.28	204	APGM063360			250			73.02	188								
APGM040250	250	41.28	214	APGM063430			280			73.02	218								
APGM040260	260	41.28	224	APGM063500			300			73.02	238								
APGM040280	280	41.28	244	APGM080200			330			73.02	268								
APGM040290	290	41.28	254	APGM080215	360	73.02	298												
APGM040300	300	41.28	264	APGM080230	430	73.02	368												
APGM040315	315	41.28	279	APGM080250	500	73.02	438												
APGM040330	330	41.28	294	APGM080280	80	80.008	79.952	79.939	93	80.008	79.952	93	200	47.6	62	138			
APGM040360	360	41.28	324	APGM080300													215	47.6	153
APGM050140	140	34.93	91	APGM080330													230	47.6	168
APGM050145	145	34.93	96	APGM080360													250	73.02	188
APGM050150	150	34.93	101	APGM080430													280	73.02	218
APGM050155	155	44.95	106	APGM080500													300	73.02	238

Commitment to Quality & Customer Satisfaction

Dayton Lamina is a leading manufacturer of tool, die and mold components for the metal-working and plastics industries. As a customer-focused, world-class supplier of choice, we provide the brands, product breadth, distribution network and technical support for all your metal forming needs.

Our goal is to give our customers the most innovative and value-added products and services.



DAYTON Lamina™

a MISUMI Group Company



Lamina® LEMPCO

*Dayton Lamina's line of Danly products is available only to North America.

www.daytonlamina.com